



# Quick Installation Guide

Cloud-Managed Wireless Ceiling Access Point



WI-AP218AX | WI-AP219AX Hardware Version: V2.0

www.wireless-tek.com

## 1.Packing Content

- WI-AP218AX | WI-AP219AX



AP x 1



Plastic Anchor x 4

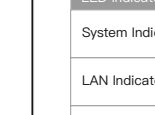

Self-Tapping Screws x 4



Ethernet Cable x 1

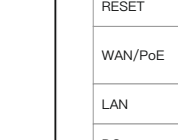

Quick Installation Guide x 1

## 2.Appearance Overview

- WI-AP218AX

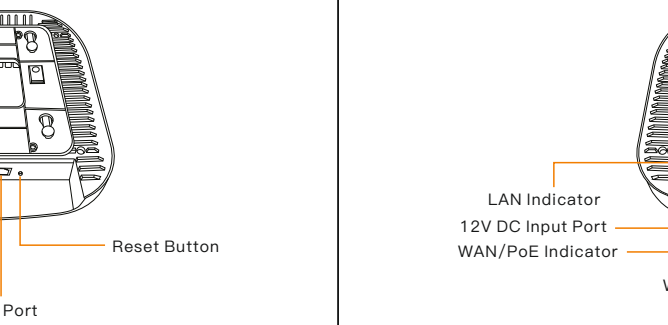

- LED indicator

LED Indicators	Status	Description
System Indicator	Off	The device is powered off.
System Indicator	On	The system is working normally.
LAN Indicator	Off	The LAN port is disconnected.
LAN Indicator	On	The LAN port is connected via Ethernet cable.
WAN/PoE Indicator	Off	The port is disconnected.
WAN/PoE Indicator	On	The port is connected via Ethernet cable.

- Port and Button

Port&Button	Description
RESET	Reset button, which is used to restore the factory. Holding down the reset button for 10 seconds to revert to factory settings.
WAN/PoE	10/100/1000Mbps Base-T Ethernet Port, which supports 802.3af/at PoE Input. If the AP is powered through PoE, please connect this port to the PoE switch supporting 802.3at output. It is generally connected to the upstream switch.
LAN	10/100/1000Mbps Base-T Ethernet port. It is generally connected to wired LAN devices such as PC.
DC	DC Input: 12V,2A The AP is powered through 12V DC Input.

## 3.Typical Connection

- Bypass mode topology

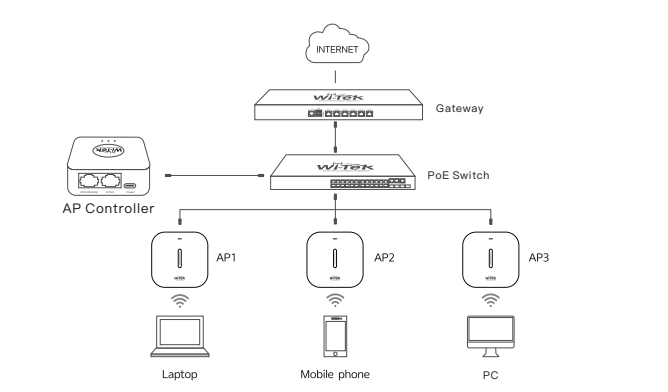

- AC Gateway mode topology

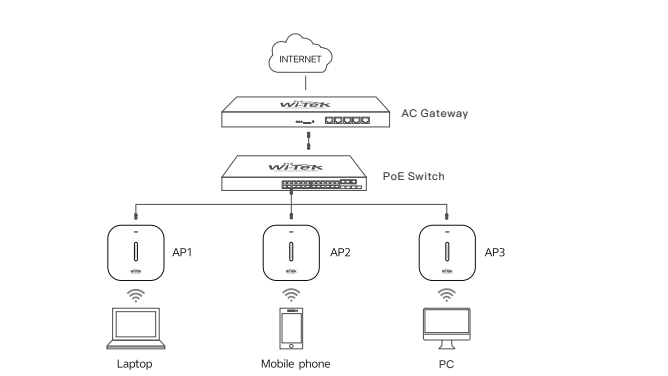

## 4.Device Installation

- Ceiling Mounting

1.Place the bracket in the center of the ceiling and then mark the positions for the screw holes and the position for Ethernet cable.

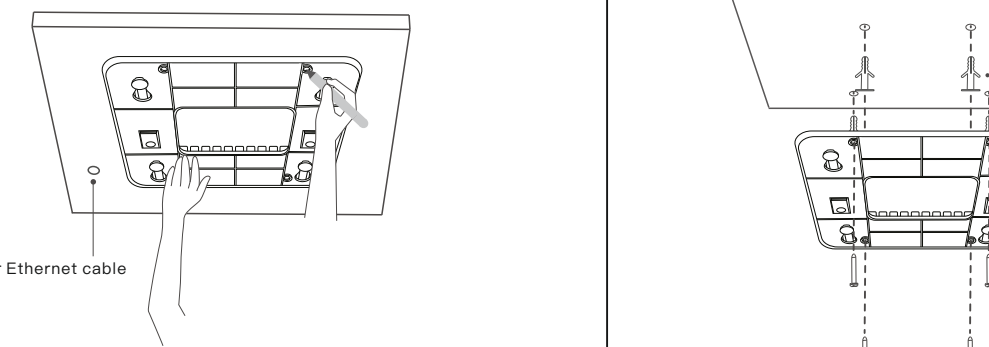

2.Drill holes in the marked positions using a hammer drill.

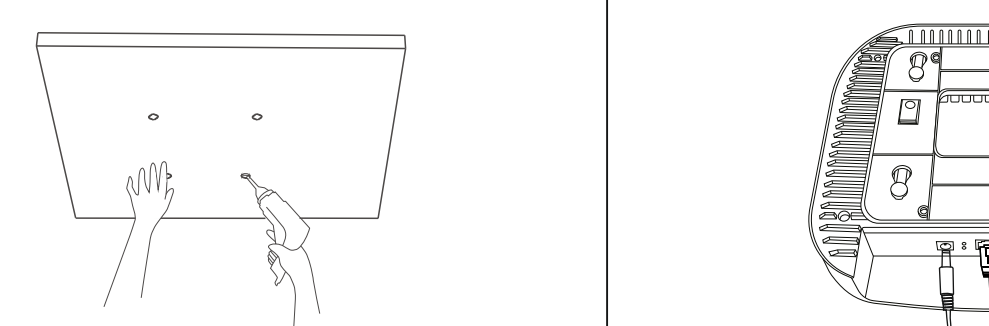

## 5.Power Supply

- Power via PSE Device

The APs can be powered via PoE switch which supports 802.3bt PoE output.

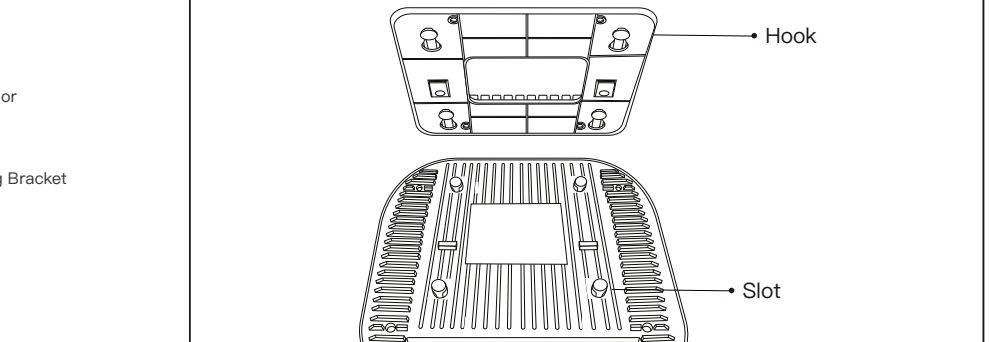

- Power via Power adapter

Some APs can be powered via power adapter which supports 12V DC output.



## 6.Configuration Method

Method 1. Connect computer to the wireless signal of AP, the default SSID is "Wi-TEK xxxx".Password is 88888888

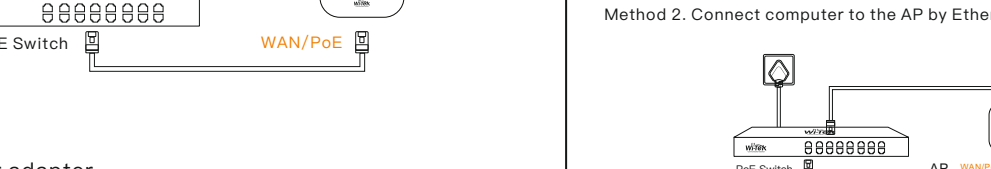
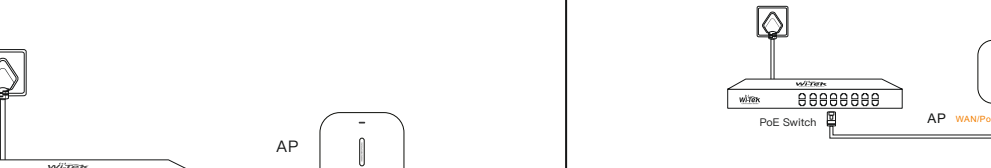

- Method 2. Connect computer to the AP by Ethernet cable.

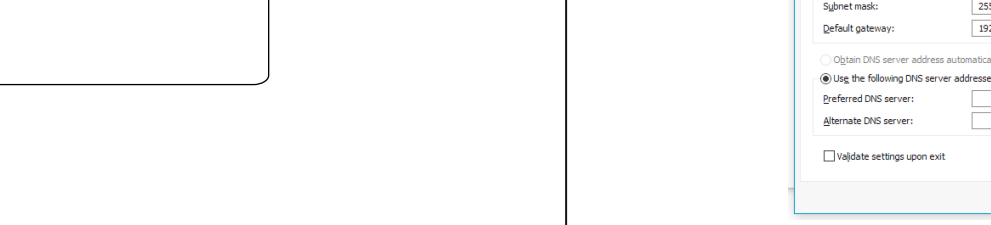
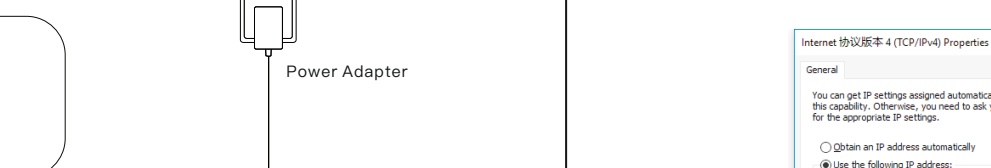

## 7.Cloud Management

Step 2. Please launch a browser such as Google Chrome or Firefox, type 192.168.1.88 into address bar and click on enter to get in the login page of wireless access point. Set the new password.

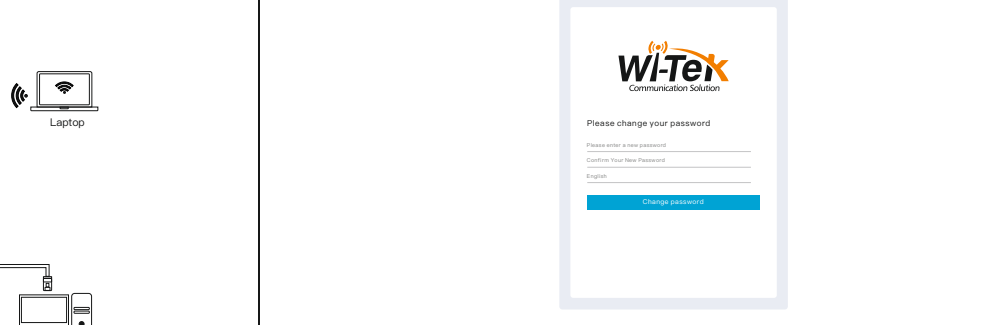

Step3. After get in the management page,On the left side menu, please go to [Wireless] to setup the access point.

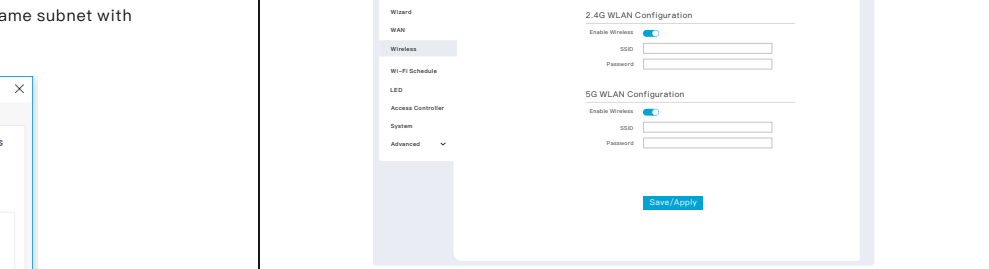

- Fit AP Mode default Login IP:192.168.1.88

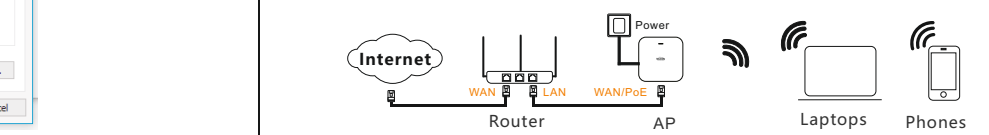

## 8.Warranty Card

3. When you find the device on the cloud topology, it means the device is successfully bound to the cloud.

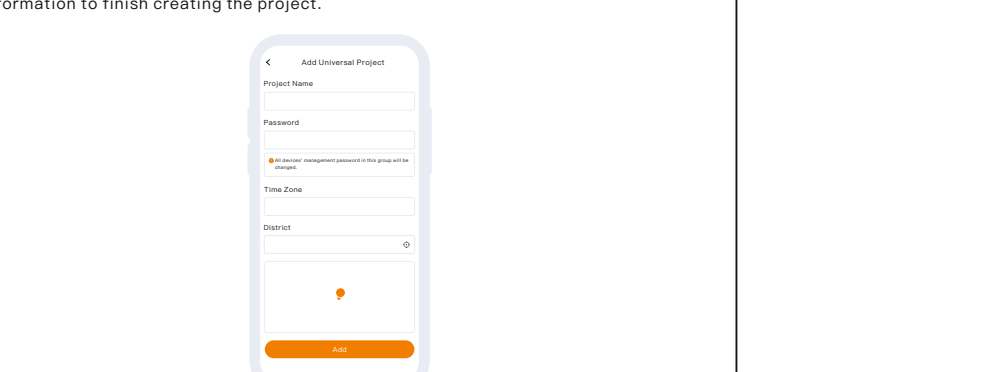

2. Enter the SN number or scan the SN barcode on the body label and click" Auto Detect". Then enter the last six digits of the MAC address for security and click " Auto Detect".

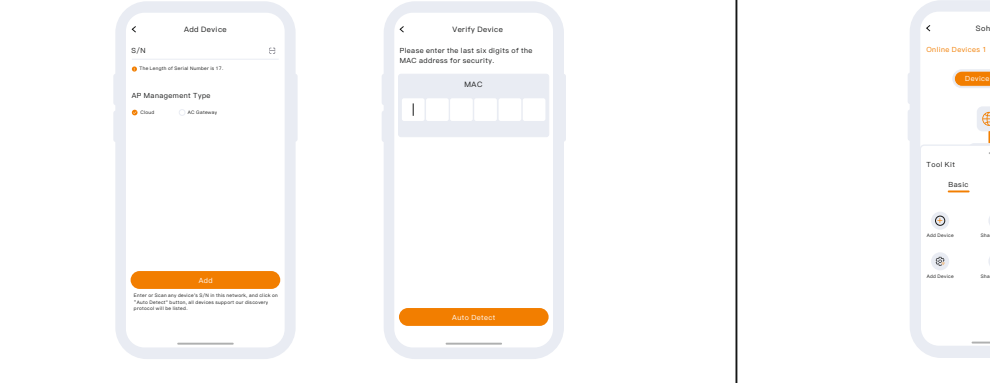

4. Click "Wi-Fi Configuration", you can make the basic wireless settings on the device.

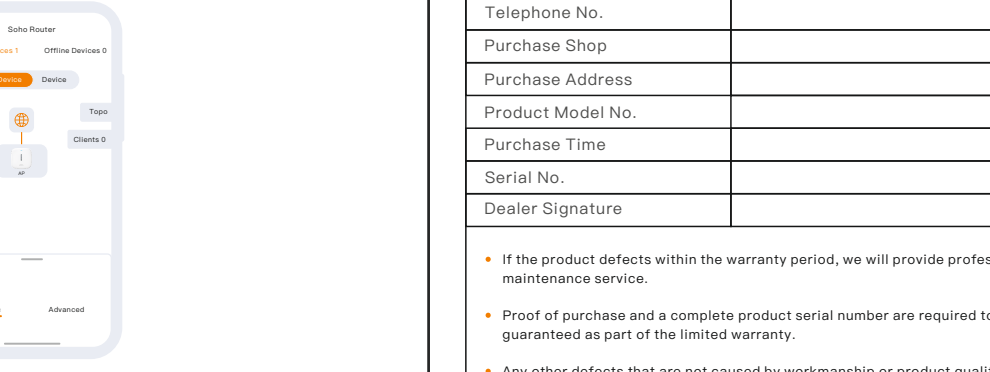

Username	
Address	
Telephone No.	
Purchase Shop	
Purchase Address	
Product Model No.	
Purchase Time	
Serial No.	
Dealer Signature	

- If the product defects within the warranty period, we will provide professional maintenance service.
- Proof of purchase and a complete product serial number are required to receive any services guaranteed as part of the limited warranty.
- Any other defects that are not caused by workmanship or product quality, such as natural disasters, water damage, extreme thermal or environmental conditions, sticker damaged, warranty card loss will disqualify the product from limited warranty.



Company Website Cloud Management Technical Support

Wireless-Tek Technology Limited  
Address: Building 3, Units 1801-1807, 1812, Huaqiang Era Plaza, Tangwei Community, Fuhai Street, Bao'an District, Shenzhen City, Guangdong Province, China.  
Website: www.wireless-tek.com  
Tel: 86-0755-32811290  
Email: sales@wireless-tek.com  
Technical Support: tech@wireless-tek.com

