

Gigabit Ethernet Switch

WI-SG116D V4 | WI-SG124D V2



Overview

Wi-Tek Gigabit Ethernet Switches provide 16/24 Gigabit Ethernet RJ-45 ports, which enhance your communication quality and supply high-performance, economic friendship, stable operating conditions for your network.

With all ports support Auto-MDI/MDIX, there's no need to worry about the type of cable to use. Featuring full duplex mode can send and receive data at a rate up to 1000Mbps, making it an ideal choice for expanding your high performance network.

Features

250m Long-Distance Extension

The DIP switch enables Extend mode, allowing all downlink ports to transmit data up to 250 meters in 10 Mbps. No additional hardware or configuration is required, making it easy to use and cost-effective—perfect for deploying surveillance cameras in large areas.

Port Isolation for Security and Broadcast Storm Prevention

With VLAN mode, all PoE ports can communicate only with uplink ports, preventing data leakage between ports and mitigating broadcast storms that could disrupt the network.

Long service Life with sturdy and durable metal shell

Wi-Tek Gigabit Ethernet Switches are protected by high-quality metal shell to ensure the long service life. They have passed a series of strict tests and provided you with reliable performance.

Environmentally friendly with your Ethernet

Wi-Tek Gigabit Ethernet Switches make use of innovative energy-saving technologies. Power consumption automatically adjusts according to link status and cable length.

Full Gigabit access, full-line speed forwarding

All ports support high-speed forwarding, user-flexibly flexible networking, to meet the needs of various scenarios networking, such as hotel, campus, factory dormitory and small and medium-sized enterprises.

Plug and Play, No Configuration Required

No professional expertise is needed—even non-technical users can easily deploy the network.

Fanless Design for Silent Operation

The fanless design ensures a quiet working environment, making it ideal for offices, hotels, and other noise-sensitive locations.

Specifications



Model	WI-SG116D	WI-SG124D
Hardware Specifications		
Hardware Version	V4	V2
Interfaces		
Downlink Ports	14 × 10/100/1000Mbps RJ45 Ports	22 × 10/100/1000Mbps RJ45 Ports
Uplink Ports	2 × 10/100/1000Mbps RJ45 Ports	2 × 10/100/1000Mbps RJ45 Ports
Switch Property		
Standards and Protocols	IEEE 802.3i, IEEE 802.3u, IEEE 802.3ab, IEEE 802.3x, IEEE 802.1p	
Forwarding Mode	Store and Forward	
Switching Capacity	32 Gbps	48 Gbps
Packet Forwarding Rate	23.8Mpps	35.71Mpps
MAC Address Table	8k	
Packet Buffer Memory	4Mbit	
Jumbo Frame	4kB	
Input Power	AC 100–240V 50/60Hz	
Physical Characteristics		
LED Indicators	<p>PWR(Green) Solid On: The device power on is normal. Off: The device is power off or failed.</p> <p>LOOP(Red) Solid On: Loop alarm. Off: No loop in the network.</p> <p>Link(Green) Solid on: The negotiated speed is 10/100Mbps and ports link up. Blinking: Data is being transmitted or received at a rate of 10/100Mbps Off: No link is established on the interface.</p> <p>1000M(Green) Solid On: The negotiated speed is 1000Mbps and ports link up. Blinking: Data is being transmitted or received at a rate of 1000Mbps. Off: The negotiated speed is 10/100Mbps, not 1000Mbps.</p>	

Model		WI-SG116D	WI-SG124D
Fan Quantity	Fanless		
Package Dimension	315*215*85mm		312*262*84mm
Switch Dimension	220*161*44.5mm		270×181×44 mm
Weight	Net Weight: ?		Net Weight: 1.18 kg
	Package Weight: ?		Package Weight: 1.74 kg
Installation	Rack-Mounted, Desktop		
Butto			
DIP Switch	Default		
	The transmission distance of the port can be up to 100m with 1000Mbps and disable VLAN, Extend mode.		
	VLAN		
	Enable VLAN mode. All downlink ports are isolated but can communicate with uplink ports.		
	Extend		
	Enable Extend mode. The transmission distance of the ports can be up to 250m, but the rate is limited to 10Mbps.		
Environmental			
Reliability	Surge Immunity	IEC 61000-4-5 Common mode 4kV Differential mode 2kV	
	ESD Protection	IEC 61000-4-2 Contact discharge 6kV Air discharge 8kV	
Operating Temperature		-10°C to 50°C(14°F to 122°F)	
Operating Humidity		10%~90% RH no condensation	
Storage Temperature		-40°C to 70°C(-40°F to 158°F)	
Storage Humidity		5%~95% RH no condensation	
Others			
Certification		CE, FCC, RoHS, UKCA, RCM	

WI-SG116D

Dimensions (mm)

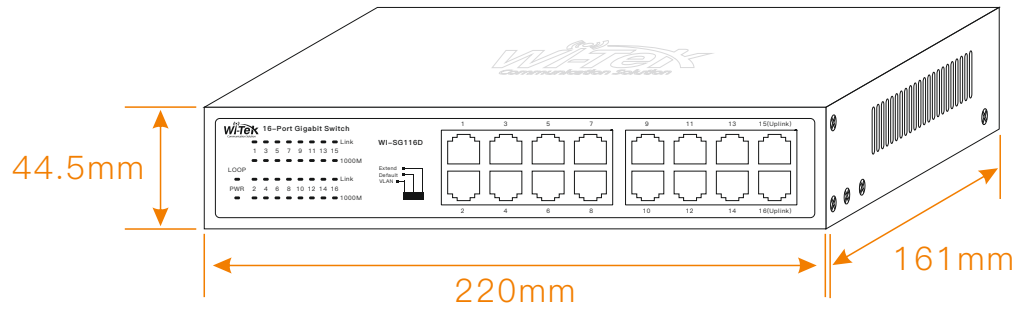

Front Panel

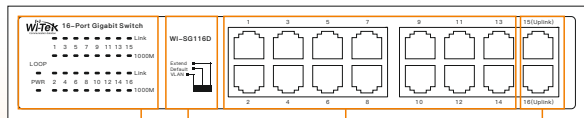

- LED Indicators
- DIP Switch
- 14*10/100/1000Mbps RJ45 Ports
- 2*10/100/1000Mbps RJ45 Uplink Ports

Rear Panel



- Grounding
- 100-240V AC Input Port

WI-SG124D

Dimensions (mm)

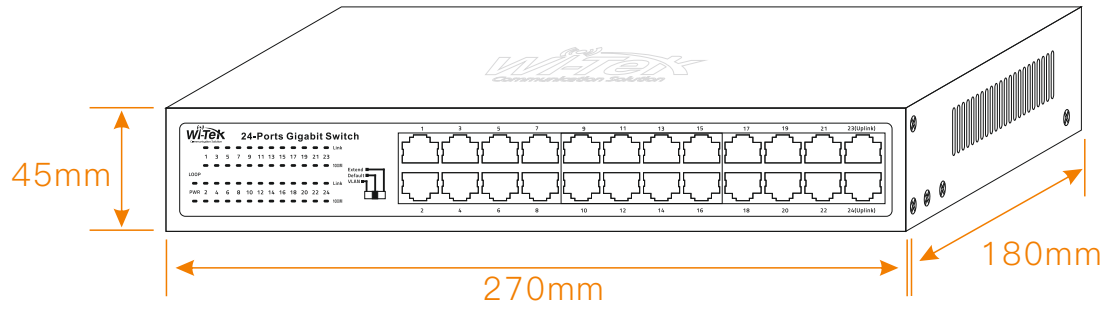

Front Panel

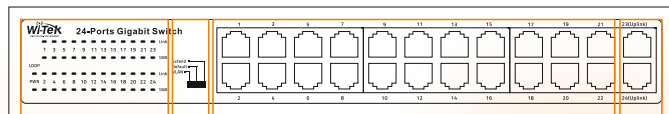

- LED Indicators
- DIP Switch
- 22*10/100/1000Mbps RJ45 Ports
- 2*10/100/1000Mbps RJ45 Uplink Ports

Rear Panel



- Grounding
- 100-240V AC Input Port

Package Contents

Welcome to order our products. After purchasing, you will receive:

Items	Quantity
Switch	1 pcs
AC Power Cord	1 pcs
Rack Mount kit	1 set
Screw	1 set
Quick Installation Guide	1 pcs



Wireless-Tek Technology Limited

Address: Building 3, Units 1801-1807, 1812, Huaqiang Era Plaza, Tangwei Community, Fuhai Street, Bao'an District, Shenzhen City, Guangdong Province, China.

Website: www.wireless-tek.com

Tel: 86-0755-32811290

Email: sales@wireless-tek.com

Technical Support: tech@wireless-tek.com



Technical Support



Cloud Management



Company Website